

# LED Indoor Luminaires Strip Light – Ceiling Mount 120-277VAC / 60Hz

Model #: LSL484100LAJD2WH-MSBB

## Safety Precautions

- Read all safety precautions and installation instructions carefully before installing or servicing this fixture. Failure to comply with these instructions could result in potentially fatal electric shock and/or property damage.
- It is recommended that a qualified electrician perform all wiring. This fixture must be wired in accordance with all national and local electrical codes.
- Do not handle any energized fixture or attempt to energize any fixture with wet hands or while standing on a wet or damp surface or in water.
- This fixture is designed for use in a 120-277VAC, 60Hz fused circuit. This fixture is not compatible on dimming circuit.
- Make sure that the power source conforms to the requirements of the fixture. (See labels on the fixture housing).
- To reduce the risk of electrical shock, and to assure proper operation, this fixture must be adequately grounded. To accomplish proper grounding, there must be a separate ground wire (green) contact between this fixture and the ground connection of your main power supply panel.
- This fixture is intended to be used for general indoor lighting in dry or damp locations.
- Disclaimer  
Changes or modifications not expressly approved by the party responsible for compliance could void the user's authority to operate the equipment. NOTE: This equipment has been tested and found to comply with the limits for a Class B digital device, pursuant to Part 15 of the FCC Rules and Canadian ICES-005 (B) / NMB-005 (B). These limits are designed to provide reasonable protection against harmful interference in a residential installation. This equipment generates, uses and can radiate radio frequency energy and, if not installed and used in accordance with the instructions, may cause harmful interference to radio communications. However, there is no guarantee that interference will not occur in a particular installation. If this equipment does cause harmful interference to radio or television reception, which can be determined by turning the equipment off and on, the user is encouraged to try to correct the interference by one or more of the following measures:
  - Reorient or relocate the receiver antenna.
  - Increase the separation between the equipment and receiver.
  - Connect the equipment into an outlet on a circuit different from that to which the receiver is connected.
  - Consult with the dealer or an experienced radio/TV technician for help.

Any modifications to this fixture may void the warranty and interfere with the safe operation of the luminaire.

Operation is subject to the following two conditions: (1) this device may not cause interference, and (2) this device must accept any interference, including interference that may cause undesired operation of the device.

## Assembly Instructions

### Step 1 – Preparing for installation

- Disconnect electrical power** at fuse or circuit breaker box before installing or servicing any part of this fixture.
- Carefully remove the fixture from the carton, remove components from hardware kit.
- Separate fixture front diffuser (4), fixture metal cover (3) and fixture channel housing (1) from each other. Detach wire connectors (5) for easier access to mount.
- Select appropriate knockout and remove for wiring connections.
- Install channel housing (1) to the ceiling over the junction box (not included) using two wood screws (2) or anchor bolts (not included) to secure it.

### Wiring – All wiring must take place inside junction box (not included)

**Caution:** Make sure power is off at fuse or circuit breaker box. Check power wires for damage or scrapes. If power supply wires are within three inches of the LED driver, use wire suitable for at least 90°C (194°F). **Note:** Most dwellings built before 1985 have supply wire rated to 60°C. Consult a qualified electrician to ensure correct branch circuit conductor before installing.

### Step 2 – Wiring fixture

- Make all wire connections to appropriate wire. Secure with wire nuts (provided).
- Connect both green leads from fixture and battery housing to the supply power source ground wire.
- Connect white battery housing lead marked "emergency driver WHITE AC-N (continuous)" to the white (N) wire from continuous supply power source.
- Connect black battery housing lead marked "emergency driver BLACK AC-L (continuous)" to the black (L) wire from continuous supply power source.
- Connect the "SWITCH LINE BLACK" from the fixture to the black (L) wire from wall switch supply power source.
- Connect the battery power cell clear connector (red and black wire) together. Note: battery power cell maybe fully charged from factory, therefore take caution as this is now fully energized and fixture will come on even under no AC power to the fixture has been restored. In the event it doesn't come on is due to low charge battery condition and will need to be recharged for 24hrs minimum to maintain fully charged when power is restored.
- Do not mix wires.** Pull on each wire lead to make sure connections are secure. Make certain no bare wires are exposed outside of wire connectors. Tuck all connections neatly into junction box.

### Step 3 – Fixture cover installation

- Ensure power mating pair connector (5) is fully connected. Slightly tilt front metal cover onto its side to engage three locking tabs on the side of the channel housing then rotate to the opposite side and squeeze the side of the channel until cover is fully secured on to the housing.

### Step 4 – Color changing temperature adjustment, CCT (if desired)

- Adjust CCT switch on the LED board to the desired color temperature of 3000K or 4000K.  
Note: Fixture is preset to 4000K from factory.

#### COLOR TEMPERATURE ADJUSTMENT SETTING

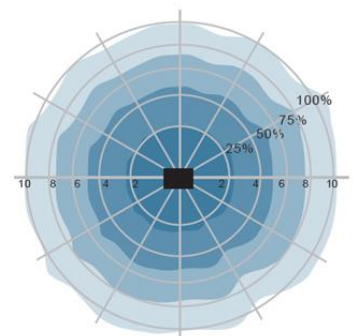
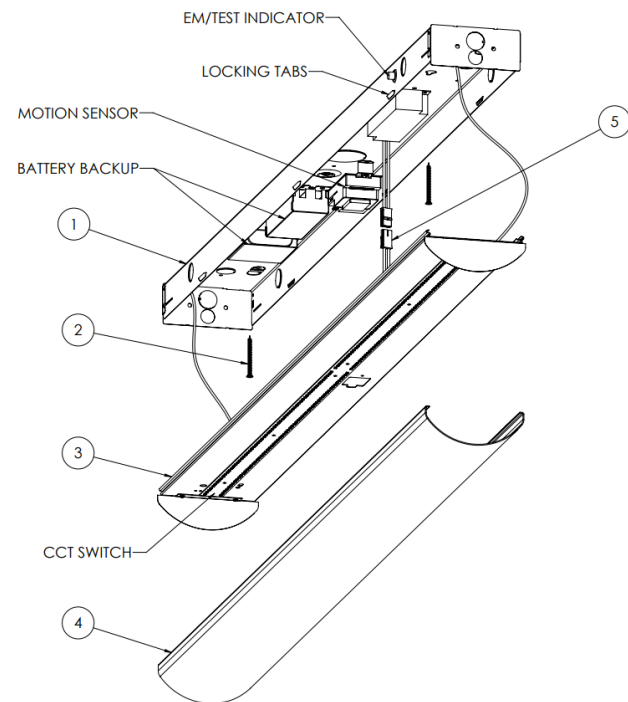
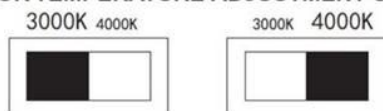

Ceiling mounting pattern (Unit: m)

# LED Indoor Luminaires Strip Light – Ceiling Mount 120-277VAC / 60Hz

Model #: LSL484100LAJD2WH-MSBB

## Step 5 – Diffuser installation

- A. Align one edge of the diffuser (4) on to the side groove of the metal cover (3). Then apply pressure on the middle of the diffuser with thumb slightly enough to expand the other side outward to catches on the opposite side. Ensure diffuser is fully secured to the metal cover.

## Step 6 – Restore power at fuse or circuit breaker box

## Step 7 – Operational Guide

- A. The red LED on the side of the fixture is an indicator for AC power status: Off – receive No AC power, On – receive AC power.  
 B. Testing battery condition regularly twice a year by pressing on the test button to check battery power cell charge status. The red LED will “turn-off” upon pressing the test button which temporary disconnect AC power and activate battery power cell. The fixture will remain lit during this testing period that indicates battery is discharging as intended. In the event there is no AC power or black out situation, fixture will remain lit for 90mins and gradually diminishing to off as battery power is depleted.

## Step 8 – Follow this guideline for alternate motion sensor setting: Ensure power to the fixture is disconnected before attempting to make any adjustment to dip switches on this fixture

### Settings

#### 1) Detection Area

	1	2	
I	ON	ON	100%
II	ON	-	75%
III	-	ON	50%
IV	-	-	10%

#### 2) Hold Time

	3	4	5	
I	ON	ON	ON	5s
II	-	ON	ON	30s
III	ON	-	ON	1min
IV	-	-	ON	3min
V	ON	ON	-	20min
VI	-	-	-	30min

#### 3) Stand-by Period

	6	7	8	
I	ON	ON	ON	0s
II	-	ON	ON	5s
III	ON	-	ON	5min
IV	-	-	ON	10min
V	ON	ON	-	30min
VI	-	ON	-	60min
VII	-	-	-	∞

#### 4) Daylight Sensor

	1	2	3	4	5	
I	ON	ON	ON	ON	ON	5lux
II	-	ON	ON	ON	ON	15lux
III	ON	-	ON	ON	ON	30lux
IV	ON	ON	-	ON	ON	50lux
V	ON	ON	ON	-	ON	100lux
VI	ON	ON	ON	ON	-	150lux
VII	-	-	-	-	-	Disable

#### 5) Detection mode

	6	
I	ON	HS
II	-	LS

#### 6) Stand-by dim Level

	1	2	
I	-	ON	50%
II	ON	-	20%
III	-	-	10%

**BATTERY PRESET INFORMATION:**

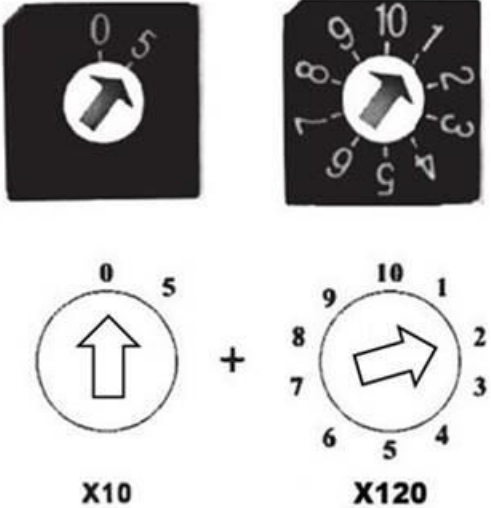
Program Switch	Features
	<p><b>Programmable Constant Current</b></p> <ul style="list-style-type: none"> <li>• Pre-set by factory</li> <li>• Adjust it by yourself</li> </ul> <p><b>Adjustable Output Current</b></p> <ul style="list-style-type: none"> <li>• 50mA per scale, 2 ranges</li> <li>• 120mA per scale, 10 ranges</li> </ul> <p><b>NOTE: FACTORY PRESET TO 240mA</b>  <b>SWITCH (0) X10 + (2) X120</b></p>

NOTE: LUMENS WILL INCREASE OR DECREASE DEPENDING ON THE PROGRAM SWITCH SETTING. MODIFYING OUTPUT CURRENT WILL INADVERTENTLY CHANGE BATTERY DISCHARGE RATE DURING POWER OUTAGES.

<b>DETECTION AREA</b>	100%
<b>HOLD TIME</b>	5S
<b>STANDBY PERIOD</b>	+ ∞
<b>DAYLIGHT SENSOR</b>	DISABLE
<b>STANDBY DIMMING LEVEL</b>	10%

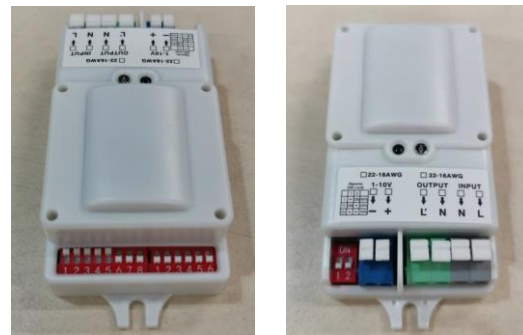

MOTION SENSOR MODULE –  
 FACTORY SETTING DETAIL

**Limited Factory Warranty**

AFX Inc. hereby warrants that this fixture is free from defects in materials and workmanship when installed and used under normal operating conditions for a period of 5 years from date of purchase. This warranty covers all component parts and extends only to replacement of defective fixture or components; it does not cover failure due to improper installation, misuse, mishandling or damage incurred in transit.